



High Pressure/High Temperature Corrosion Testing Rotating Cylinder Electrode (RCE)

Based on our popular 1 liter stirred reactor, Parr's RCE system includes a rotating cylinder electrode, along with static high pressure reference and counter electrodes. The base system, with all wetted components constructed of Alloy C276, is rated for use up to 200 bar (2900 psi) at 200 °C, with rotational speeds up to 2000 rpm. Please contact us for higher speed options.

This fully integrated system includes the RCE vessel assembly with probes and stand, 4848 Temperature/Motor Controller, Gamry Interface 1010B Potentiostat, and control & logging software.

Parr's software allows simple measurement of open circuit potential (OCP), and performance of linear polarization resistance (LPR) and electrochemical impedance spectroscopy (EIS) studies at multiple rotational speeds, all with the touch of a button.

Many other features and specifications are also customizable. Contact us today to discuss your research needs.



RCE shown with
Parr 4848 Controller
and Potentiostat

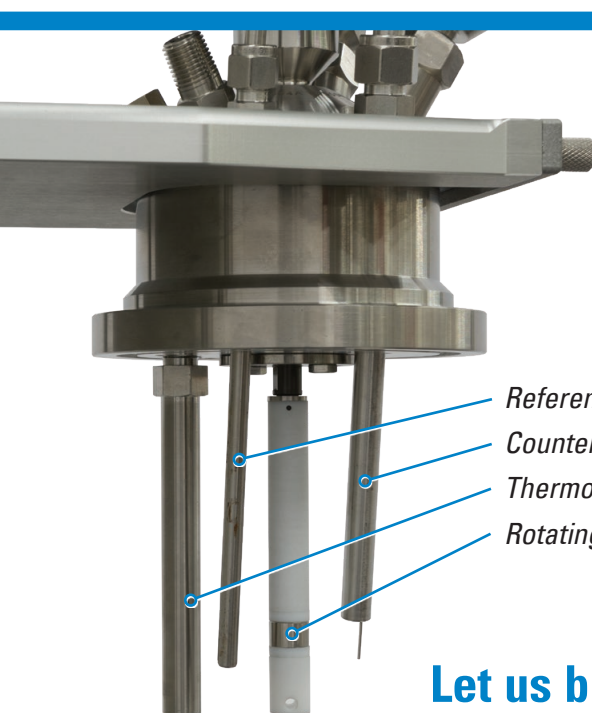

- Reference Electrode*
- Counter Electrode*
- Thermowell*
- Rotating Cylinder Electrode*

Let us build one for you.

RCE Specifications

Max Allowable Working Pressure	2900 psi (200 bar)
Max Allowable Working Temperature	200 °C
Material of Construction	C276/PEEK
Maximum RCE Speed	2000 RPM
Counter Electrode	Pt
Reference Electrode	Ag/AgCl
Potentiostat	Gamry 1010B
Control/Logging Software	SpecView