



MILESTONE
H E L P I N G
C H E M I S T S



UltraCLAVE

Simultaneous, Fully Automated
Microwave Digestion System

The next generation microwave digestion system

The UltraCLAVE performs beyond the current limitations of traditional microwave sample preparation.

It offers all the advantages familiar to microwave users: speed, quality of results, reproducibility, and no pollution of the laboratory or environment, while overcoming the restrictions of traditional microwave digestion systems.

The UltraCLAVE improves upon this established technology by changing the rules; it is based on high pressure autoclave design: at its heart a single large reaction sample-containing chamber is pre-pressurized with inert gas and then heated by microwaves. The pressurized chamber serves simultaneously as the microwave cavity and the reaction vessel.

Chemists can digest large sample masses, large batches of mixed sample types, and even the toughest sample matrices requiring sustained high temperatures.

Cross-contamination does not occur and extremely high throughput can be achieved.

Finally, reduced acid usage, consumables, and need for labor provide long-term cost savings.

It is the truly next generation microwave digestion system.



The unique UltraCLAVE technology

The patented Milestone UltraCLAVE achieves extraordinary performance capabilities by combining direct microwave heating in a high pressure reactor, which acts simultaneously as microwave cavity and vessel.

Microwave energy is introduced into the reactor through a unique microwave port.

This focused-multimode cavity design ensures maximum sample heating efficiency.

Heat generated in the reactor is removed by a re-circulating cooling system, and the stainless steel vessel remains at approximately room temperature throughout the entire heating cycle.

The UltraCLAVE is designed for simplicity of use.

Loading a rack of samples into the chamber is the only manual operation required and can be done in a single motion.

The reaction chamber is sealed, pressurized, heated, cooled, vented, and opened all under computer control.

As a result, the system dramatically reduces the need for labor compared to conventional microwave systems.

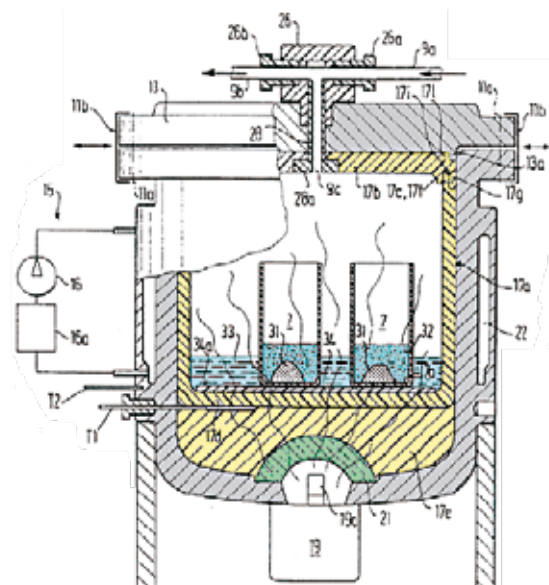

Patents:

US 5,382,414-5,725,835

Germany 4105094-4114525

Europe EP0728038-W09513133

Automatic operation

Once the vessels rack is placed in the UltraCLAVE reactor (1), all subsequent steps are automatically performed and controlled by the system operating software.

The reaction chamber lifts up to dock with the cover (2), creating a pressure seal that is secured in place by steel clamps.

Once the chamber is sealed, a high-performance compressor pressurizes the system with inert gas (3).

A microwave program, controlling temperature, pressure, and microwave power versus time, is then initiated via the control terminal.

During the run, integrated sensors continuously monitor and display the internal pressure and sample temperature.

The UltraCLAVE software dynamically adjusts the applied microwave power in real time to precisely follow the defined temperature profile (4).

At the completion of the heating process the reactor and its contents are cooled by an integrated chilling unit, the pressure inside the reactor is released (5), and the remaining process vapors are safely exhausted.

Only after ambient pressure is reached, the sealing clamps are released (6).

The reactor body is then lowered, and the digested samples can be removed.

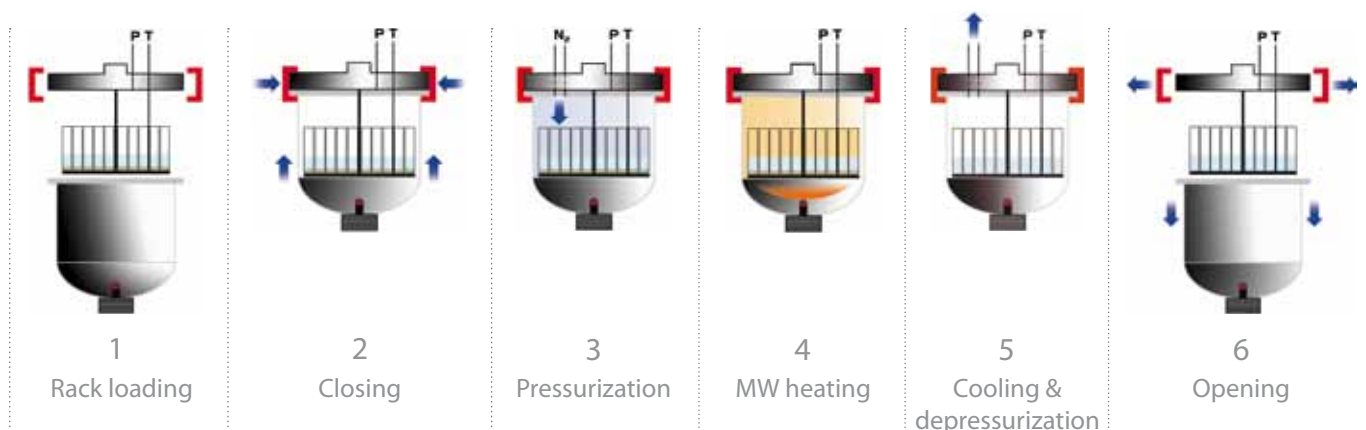

Wide choice of digestion vessels

With the UltraCLAVE it is possible to process a single, very large sample in a TFM liner fitted to the entire reaction chamber.

The individual sample containers can be much simpler in design than in conventional microwave vessel assemblies.

As a result, a higher batch count of discrete samples can be accommodated.

Another benefit is the vastly reduced need for consumable vessel components: since the combination of pre-pressure nitrogen and partial pressure of process vapors ensures that boiling never occurs in individual sample containers.

Several standard racks are designed to hold 6 to 77 individual sample containers made of glass, quartz, or TFM.



Highest digestion quality

Traditional closed-vessel microwave proceeds by monitoring and controlling conditions in a single reference vessel.

The assumption is that these parameters can be duplicated in all other vessels that are processed along with the reference vessel.

In order for this to be true, the sample type, sample mass and the volume of acid must be identical to that in the reference vessel.

In the UltraCLAVE no single vessel is selected as the reference. Instead, uniform temperature conditions are achieved they are monitored and controlled throughout the heating process.

By eliminating the traditional control strategy, chemists are no longer constrained to process batches of identical samples using identical sample chemistries.

Therefore, many dissimilar samples and chemistries can be combined in a single run in the UltraCLAVE.

Even certified reference materials can be processed along with unknown sample for method validation.

This transformation of a sequential process into a parallel one may prove to be the greatest source of increased efficiency in many laboratories.

Applications

Materials testing



When testing materials for RoHS Directive compliance, the UltraCLAVE can accommodate the entire range

of sample types subject to the regulation. Its ability to digest mixed batches allows a variety of components to be processed at the same time.

Clinical



The UltraCLAVE provides the simultaneous digestion of multiple sample types

(blood, urine, hair), reduces acid usage even further, and processes more samples in less time, reducing the daily operating costs.

Polymers



A fundamental part of polymer QA/QC is the need to digest or extract large sample

masses. The UltraCLAVE can digest 25 to 30 g, distributed among multiple vessels.

Environmental



In a busy environmental laboratory, sample preparation is always the bottleneck that determines how

much analytical work can be done. The UltraCLAVE handles large batches of samples in a variety of types (soils, vegetation, drinking water, wipes, and swipes) with faster turnaround and with no loss of volatiles.

Remediation



Soils, sand, cement, organics, and a host of other materials all come into the laboratory at

once to be prepared for analysis. The UltraCLAVE can handle these samples simultaneously, in batches of up to 77 mixed samples, and with minimal dilution.

Food and Feed



Organic samples can be easily prepared with the UltraCLAVE, at substantially

higher temperatures than those obtainable with traditional microwave systems, thus assuring complete digestions.



The UltraCLAVE benefits

- » Highest sample amount
- » Highest sample throughput
- » Highest temperature and pressure
- » Same conditions for all samples
- » Minimal required labor and lowest running cost
- » Full automation
- » Full documentation

UltraCLAVE Labstation

Hardware

- High pressure stainless steel reactor with 3,5 liters TFM liner

Cover lift mechanism

- Auto-lift and clamps controlled by electronic position sensors

Microwave power

- Fully programmable from 0 to 1200 Watt at 2450 MHz frequency

Microwave coupling

- Directly to pressure reactor

Vessel cooling

- Closed-loop cooling system

Operating software

- Via external Windows™-based computer through dedicated software

Maximum temperature

- 260°C for extended time

Maximum pressure

- 200 bar

Vessel safety and test certifications

- Hydrostatically tested at 315 bar for German TUV certification

Weight and dimensions

- Weight ~ 400 kg
- Dimensions 64 x 100 x 164 (h) cm
- Power 220V/50Hz, 2,4 kW

Control terminal PCE with:

- 15" large high resolution color screen
- 'Touch-control' display
- Windows™ operating system
- Keyboard and mouse
- Interfaces for microwave unit, USB port, balance (serial), Ethernet RJ45
- Dimensions 35 x 27,5 x 7,5 (h) cm
- Weight of approximately 4,5 kg

Specifications are subject to change without notice.

MILESTONE



HELPING
CHEMISTS

MILESTONE Srl - Via Fatebenefratelli, 1/5 - 24010 Sorisole (BG) - Italy
Tel: +39 035 573857 - Fax: +39 035 575498
www.milestonesrl.com - email: analytical@milestonesrl.com

UNI EN ISO 9001:2008 CERTIFIED - Registration N° 0513907

MILESTONE INC. - 25 Controls Drive - Shelton, CT 06484 - USA
Tel: (203) 925-4240 - Toll-free: (866) 995-5100 - Fax: (203) 925-4241
www.milestonesci.com - email: mwave@milestonesci.com

MILESTONE GENERAL K.K. - KSP, 3-2-1, Sakado - Takatsu-Ku,
Kawasaki 213-0012 - Japan - Tel: +81 (0)44 850 3811 - Fax: +81 (0)44 819 3036
www.milestone-general.com - email: info@milestone-general.com

MLS GmbH - Auenweg 37 D-88299 Leutkirch im Allgäu - Germany
Tel: +49 (0)7561 9818-0 - Fax: +49 (0)7561 9818-12
www.mls-mikrowellen.de - email: mws@mls-mikrowellen.de

In your country:

